



深圳市中顺半导体照明有限公司

—ShenzhenZhongshunSemiconductorLightingCo.,Ltd.—

Specification

规格书

Customer Name: _____

客户名称

Customer P/N: _____

客户品号

Factory Model: _____ S-G2835*E***P3

公司型号

Sending Date: _____

呈送日期

R&D 研发规格书

Sample 样品规格书

Product 产品规格书

Customer Approval

客户审核

ZS Approval

中顺审核

Approval

核准

Audit

确认

Confirmation

制作

Approval

核准

Audit

确认

Confirmation

制作

Qualified

授受

Disqualified

不接受

Date:

日期:

Address: MeiXun Technology Park, No. 19, Jinxiu Middle Road, Pingshan District, Shenzhen

地址: 广东省深圳市坪山区锦绣中路 19 号美讯科技园

Tel/联系电话: 400-088-2835 Web/网址: www.zsled.com.cn



LM-80

EN 62471



Contents 目录

Version history 修订履历.....	3
Features 特征.....	4
Application 应用.....	4
Package dimension 封装尺寸.....	4
Product number explanation 产品编码说明.....	5
Table of color temperature 色温表.....	5
Table of color rendering index 显指表.....	5
Table of specifications 规格表.....	5
Absolute maximum ratings 绝对最大额定值.....	6
Electrical-Optical characteristics 电性与光学特性.....	6
Luminous Intensity Rank 亮度等级.....	7
Forward voltage rank 电压等级.....	7
CIE chromaticity diagram 色区图.....	7
Typical optical characteristics curves 典型光学特性曲线.....	9
Reliability test items and conditions 信赖性测试项目及条件.....	10
Label dxplanation 标签说明.....	11
Reel dimensions 卷盘尺寸.....	11
Carrier tape dimensions 载带尺寸.....	12
Moisture resistant packing process 防潮包装过程.....	12
Precautions for use over-current-proof 通电使用时的注意事项.....	13
Storage 存储.....	13
Soldering condition 焊接条件.....	13
Soldering iron 烙铁焊接.....	14
Repairing 返修.....	14
Cautions 使用注意事项.....	14

Features (特征)

1. PLCC-2 package (PLCC-2 封装)
2. Top view white LED (平面式白光 LED)
3. Wide viewing angle (大角度发光)
4. RoHS compliant (符合 RoHS 标准)
5. Package: 17000pcs/reel (包装每卷 17000PCS)

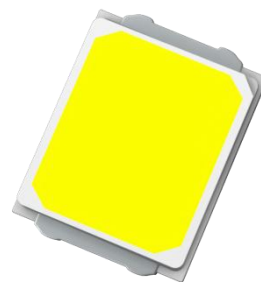

Application (应用)

1. General lighting (普通照明)
2. Optical indicator (光学指示)
3. Switch Lights (开关照明)
4. Decorative and Entertainment Lighting (装饰与娱乐照明)

Package Dimension (封装尺寸)

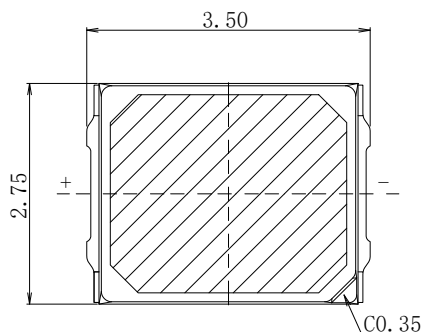

1-1 Top view 正视图

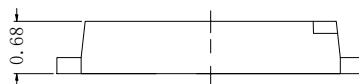

1-2 Side view 侧视图

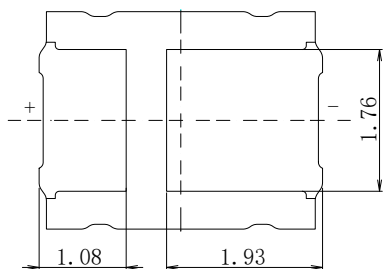

1-3 Bottom view 背视图

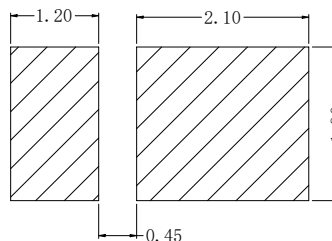

1-4 Soldering patterns 推荐焊盘

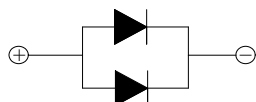

1-5 Polarity 极性

Notes (备注):

1. All dimensions are in millimeters (所有标注尺寸单位为毫米)
2. Tolerances are $\pm 0.15\text{mm}$ unless otherwise noted (除特别标注外, 允许公差为 $\pm 0.15\text{mm}$)



Product Number Explanation (产品编码说明)

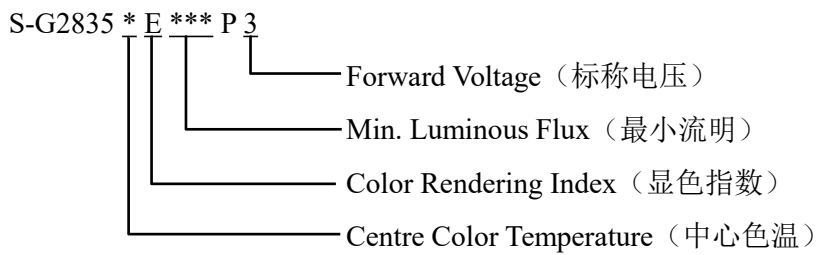

Table of Color Temperature (色温表)

Symbol (符号)	Color	Centre Color temperature
P	Pure White (正白)	4700K ≤ CCT < 7500K
N	Neutral White (自然白)	3700K < CCT < 4700K
W	Warm White (暖白)	2300K ≤ CCT ≤ 3700K
C	Cool White (冷白)	7500K ≤ CCT

Table of Color Rendering Index (显指表)

Symbol (符号)	Description (描述)
S	CRI (Min.): 70
E	CRI (Min.): 80 / R9 > 0
R	CRI (Min.): 80 / R9 < 0
N	CRI (Min.): 90
T	CRI (Min.): 95

Table of Specifications (规格表)

NO.	P/N	Model	Color	Rendering Index	Min. Luminous Flux
1					120
2					130
3		S-G2835PExxP3	Pure White	Min.80	140
4					150
6					120
7					130
8		S-G2835NExxP3	Neutral White	Min.80	140
9					150
11					110
12					120
13		S-G2835WExxP3	Warm White	Min.80	130
14					140

Absolute maximum ratings @ T_a=25°C (绝对最大额定值)

Item (项目)	Symbol (符号)	Absolute Maximum Rating (数值)	Unit (单位)
Forward Current (正向电流)	I _F	300	mA
Pulse Forward Current (脉冲正向电流)	I _{FP}	350	mA
Reverse Voltage (反向电压)	V _R	9	V
Power Dissipation (功率消耗)	P _D	900	mW
Operating Temperature (工作温度)	T _{opr}	-30~+85	°C
Storage Temperature (储存温度)	T _{stg}	-30~+100	°C
Junction Temperature (结温)	T _J	125	°C
Thermal Resistance (热阻)	R _{th}	20	°C/W
Electrostatic Discharge (静电)	ESD	2000 (HBM)	V
Solder Joint Temperature (焊点推荐温度)	T _{sp}	105	°C

Electrical-Optical characteristics @T_a=25°C (电性与光学特性)

Item (项目)	Symbol (符号)	Code (代码)	Test Condition (测试条件)	Min (最小)	Typ (平均)	Max (最大)	Unit (单位)
Forward Voltage (正向电压)	VF	-	IF=300mA	3.0	-	3.4	V
Color Temperature (色温)	CCT	A65-5	IF=30mA	6100	-	6900	K
		40-5	IF=30mA	3780	-	4250	K
		A30-5	IF=30mA	2910	-	3190	K
Reverse Current (反向电压)	IR	-	VR=9V	-	-	1	μA
Color Rending Index (显指)	Ra	Pure/Neutral /Warm	IF=300mA	80	-	-	
View Angle (角度)	2θ _{1/2}	-	IF=300mA	-	120	-	deg
CIE Chromaticity (色坐标)	x y	/ /	IF=300mA	Please see the bin sorting standard			

Notes (备注):

1. Tolerance of Forward voltage (VF) : ±0.1V
正向电压允许公差: ±0.1V
2. Tolerance of Luminous Flux (φ_v) : ±3%
流明允许公差: ±3%
3. Tolerance of Color Temperature (CCT) : ±2%
色温允许公差: ±2%
4. Tolerance of Color Rending Index (Ra) : ±2
显指允许公差: ±2

Luminous Intensity Rank @ $T_a=25^\circ\text{C}$ (亮度等级)

Model	Min.	Max.	Unit	Condition
2700-3000K	110	120	lm	$I_F=300\text{mA}$
4000-6500K	120	130		
2700-3000K	120	130		
4000-6500K	130	140		
2700-3000K	130	140		
4000-6500K	140	150		
2700-3000K	140	150		
4000-6500K	150	160		

Forward Voltage Rank @ $T_a=25^\circ\text{C}$ (电压等级)

NO.	Min.	Max.	Unit	Condition
1	3.0	3.1	V	$I_F=300\text{mA}$
2	3.1	3.2		
3	3.2	3.3		
4	3.3	3.4		

CIE Chromaticity Diagram @ $I_F=300\text{mA}$, $T_a=25^\circ\text{C}$ (色区图)

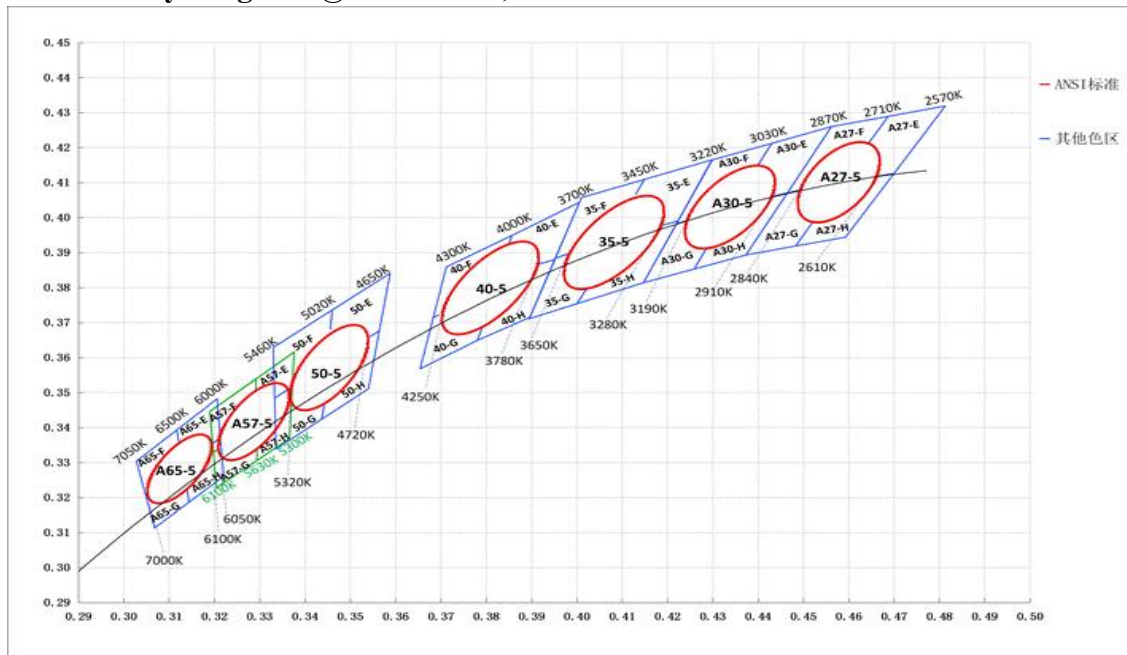

Main color BIN	x	y	a	b	θ	SDCM	Refer to CCT	
A65-5	0.3123	0.3282	0.00223	0.00095	58.38	5	6300-6800K	
Other color BIN	x1	y1	x2	y2	x3	y3	x4	y4
A65-E	0.3206	0.3482	0.3117	0.3393	0.3131	0.3290	0.3213	0.3371
A65-F	0.3117	0.3393	0.3028	0.3304	0.3048	0.3209	0.3131	0.3290
A65-G	0.3131	0.3290	0.3048	0.3209	0.3068	0.3113	0.3144	0.3187
A65-H	0.3221	0.3261	0.3144	0.3187	0.3131	0.3290	0.3213	0.3371

Main color BIN	x	y	a	b	θ	SDCM	Refer to CCT	
A57-5	0.3287	0.3417	0.002486	0.001066	59.09	5	5400-5900K	
Other color BIN	x1	y1	x2	y2	x3	y3	x4	y4
A57-E	0.3376	0.3616	0.3292	0.3539	0.3293	0.3419	0.3371	0.3493
A57-F	0.3190	0.3446	0.3198	0.3329	0.3293	0.3419	0.3292	0.3539
A57-G	0.3204	0.3228	0.3294	0.3306	0.3293	0.3419	0.3198	0.3329
A57-H	0.3293	0.3419	0.3294	0.3306	0.3366	0.3369	0.3371	0.3493

Main color BIN	x	y	a	b	θ	SDCM	Refer to CCT	
50-5	0.3454	0.3572	0.00274	0.00118	59.62	5	4800-5200K	
Other color BIN	x1	y1	x2	y2	x3	y3	x4	y4
50-E	0.3449	0.3581	0.3460	0.3736	0.3588	0.3841	0.3564	0.3676
50-F	0.3333	0.3484	0.3330	0.3629	0.3460	0.3736	0.3449	0.3581
50-G	0.3333	0.3484	0.3336	0.3339	0.3437	0.3424	0.3449	0.3581
50-H	0.3437	0.3424	0.3449	0.3581	0.3564	0.3676	0.3540	0.3511

Main color BIN	x	y	a	b	θ	SDCM	Refer to CCT	
40-5	0.3809	0.3799	0.00313	0.00134	54.00	5	3800-4200K	
Other color BIN	x1	y1	x2	y2	x3	y3	x4	y4
40-E	0.3818	0.3793	0.3857	0.3949	0.4006	0.4044	0.3951	0.3880
40-F	0.3683	0.3714	0.3712	0.3859	0.3857	0.3949	0.3818	0.3793
40-G	0.3654	0.3568	0.3683	0.3714	0.3818	0.3793	0.3780	0.3649
40-H	0.3780	0.3649	0.3818	0.3793	0.3951	0.3880	0.3896	0.3715

Main color BIN	x	y	a	b	θ	SDCM	Refer to CCT	
35-5	0.4082	0.3929	0.00317	0.00139	52.97	5	3280-3650K	
Other color BIN	x1	y1	x2	y2	x3	y3	x4	y4
35-E	0.4075	0.3932	0.4149	0.4109	0.4298	0.4165	0.4223	0.3990
35-F	0.3953	0.3884	0.4010	0.4057	0.4149	0.4109	0.4075	0.3932
35-G	0.3895	0.3711	0.3953	0.3884	0.4075	0.3932	0.4000	0.3754
35-H	0.4000	0.3754	0.4075	0.3932	0.4223	0.3990	0.4147	0.3814

Main color BIN	x	y	a	b	θ	SDCM	Refer to CCT	
A30-5	0.4338	0.4030	0.00278	0.00136	53.17	5	2950-3150K	
Other color BIN	x1	y1	x2	y2	x3	y3	x4	y4
A30-E	0.4342	0.4027	0.4430	0.4212	0.4562	0.4260	0.4465	0.4071
A30-F	0.4221	0.3984	0.4299	0.4165	0.4430	0.4212	0.4342	0.4027
A30-G	0.4221	0.3984	0.4147	0.3814	0.4259	0.3853	0.4342	0.4027
A30-H	0.4342	0.4027	0.4259	0.3853	0.4373	0.3893	0.4465	0.4071

Main color BIN	x	y	a	b	θ	SDCM	Refer to CCT	
A27-5	0.4578	0.4101	0.00258	0.00137	57.28	5	2650-2800K	
Other color BIN	x1	y1	x2	y2	x3	y3	x4	y4
A27-E	0.4813	0.4319	0.4687	0.4289	0.4582	0.4098	0.4700	0.4126
A27-F	0.4687	0.4289	0.4562	0.4260	0.4465	0.4071	0.4582	0.4098
A27-G	0.4373	0.3893	0.4465	0.4071	0.4582	0.4098	0.4483	0.3919
A27-H	0.4700	0.4126	0.4582	0.4098	0.4483	0.3919	0.4593	0.3944

Notes (注释): 1.Main color BIN 主色区; 2.Other color BIN:其他色区 3.Refer to CCT 参考色温。

Typical optical characteristics curves @ $T_a=25^{\circ}\text{C}$ (典型光学特性曲线)

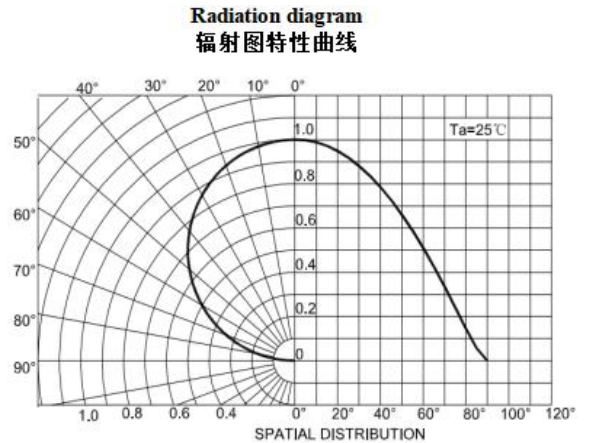
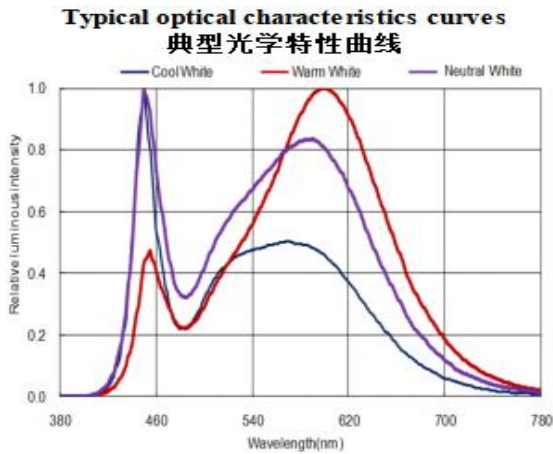
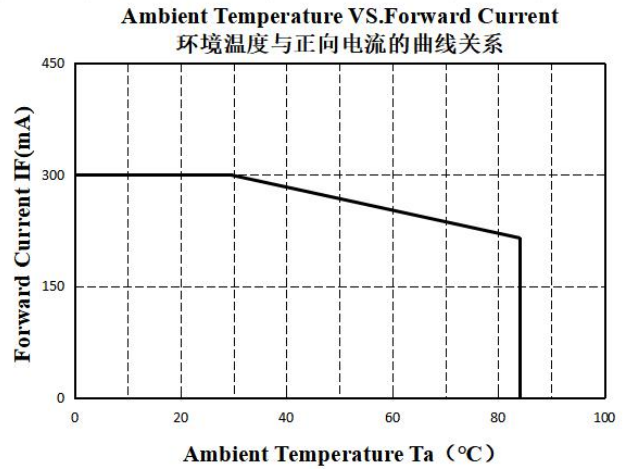
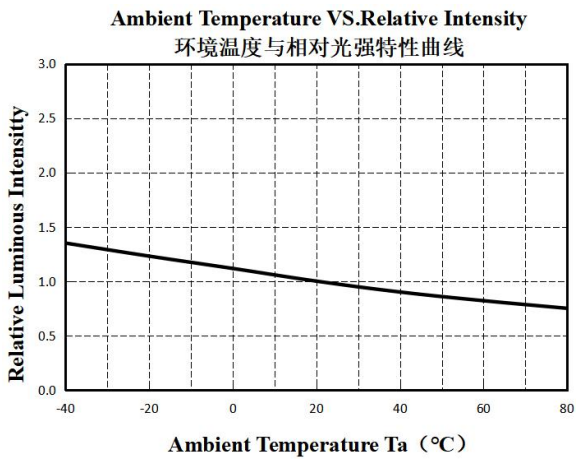
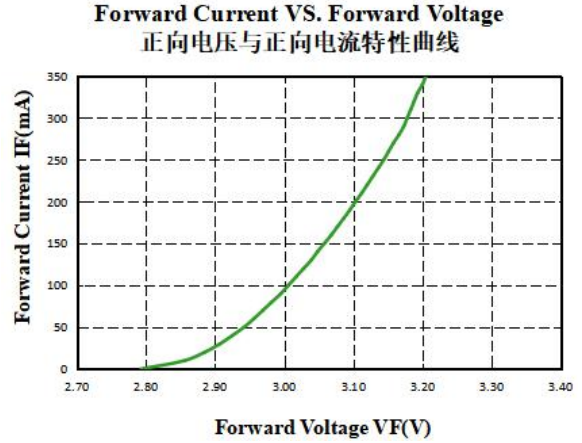
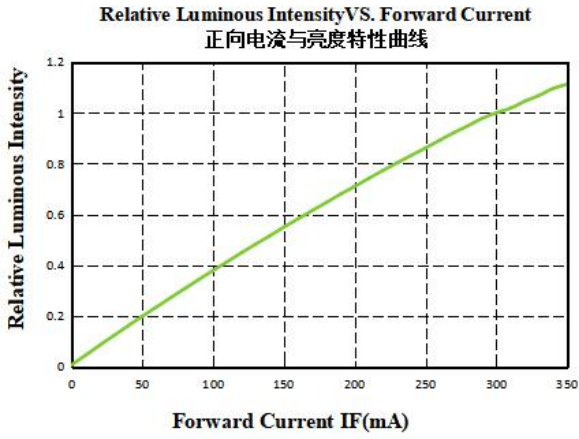



Reliability Test Items And Conditions (信赖性测试项目及条件)

Test Item (项目)	Ref.Standard (参考标准)	Test Conditions (测试条件)	Time (时间)	Quantity (pcs) (数量)
High Temperature Storage (高温储存)	JESD22-A103	Temp:100°C±5°C	1000 hrs	22
Low Temperature Storage (低温储存)	JESD22-A119	Temp:-40°C±5°C	1000 hrs	22
Thermal Shock (冷热冲击)	JESD22-A104	100°C±5°C 30min ↓↑15S -40°C±5°C 30min	200 cycle	22
Reflow (回流焊)	JESD22-B106	Temp:max260°C Time:10sec 8min/cycle	3 cycle	22
Life Test (常温老化)	JESD22-A108	Ta=25°C±5°C IF=300mA	1000 hrs	22
High Temperature Life Test (高温老化)	JESD22-A108	Ta=105°C±5°C IF=300mA	1000 hrs	22
High Temperature High Humidity Life Test (高温高湿老化)	JESD22-A101	85°C±5°C/85%RH I _F =300mA	1000 hrs	22

Criteria For Judging Damage (失效判定标准)

Item (项目)	Symbol (符号)	Test Conditions (测试条件)	Criteria for Judgement (判定标准)	
			Min. (最小)	Max. (最大)
Forward Voltage (正向电压)	VF	IF=300mA	—	(U.S.L*) × 1.1
Luminous Intensity (光通量)	ΦV	IF=300mA	(L.S.L*) × 0.7	—

Note (备注):

U.S.L.:Upper Standard Level (规格上限)

L.S.L.:Lower Standard Level (规格下限)

Label Explanation (标签说明)

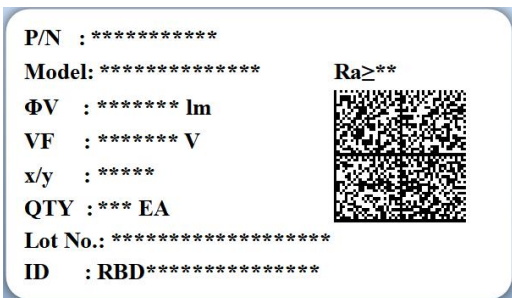

P/N:Part number (产品料号)

Model:Product model (产品型号)

ΦV:Luminous Intensity rank (流明)

VF:Forward Voltage (电压)

x/y:Color BIN (色区)

QTY:Number of packages (数量)

Lot NO.:Lot number (批号)

ID:Identification (标识号)

Reel Dimensions (卷盘尺寸)

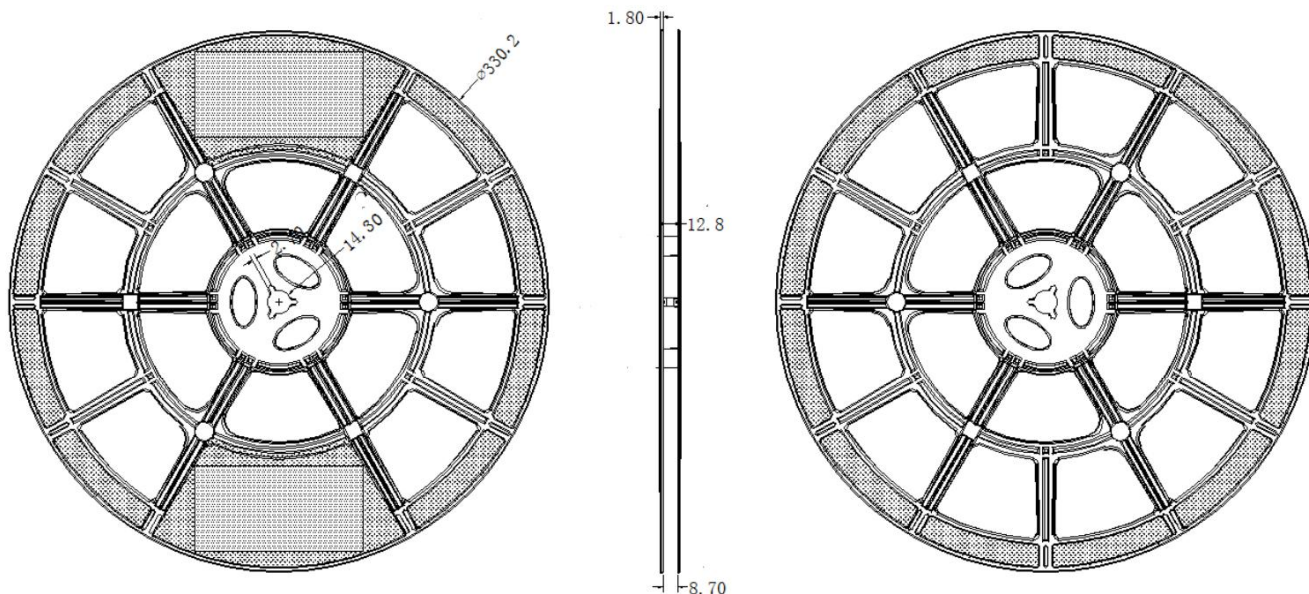

Note (备注) :

- 1. Tolerance unless mentioned is ±0.3mm; unit=mm
 未标注公差为±0.3mm, 尺寸单位: mm

Carrier Tape Dimensions (载带尺寸)

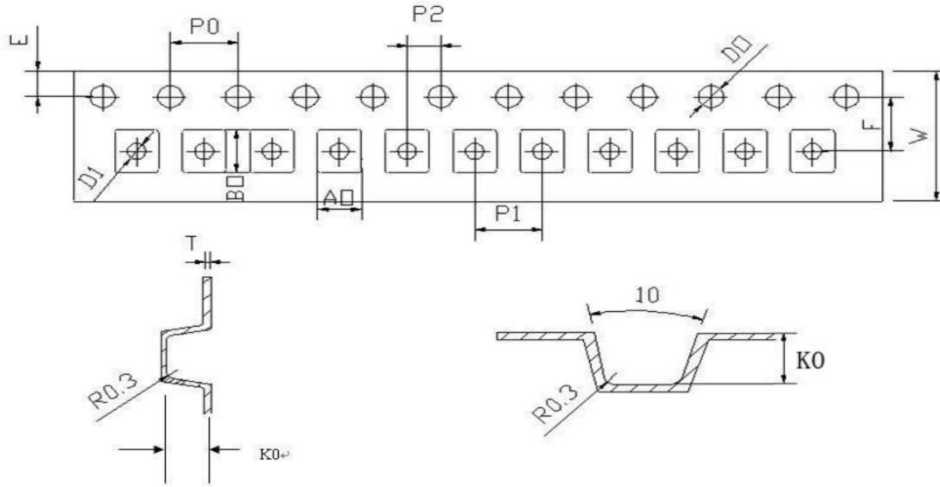

W	8.00±0.10	E	1.75±0.10	P0	4.00±0.10	A0	3.00±0.10
T	0.20±0.03	F	3.50±0.10	P1	4.00±0.10	B0	3.75±0.10
D1	1.10±0.05	D0	1.60±0.10	P2	2.00±0.05	K0	0.95±0.10

Note (备注) :

1. Tolerance unless mentioned is ±0.1mm; unit=mm.
允许公差为 ±0.1mm, 单位 mm

Moisture Resistant Packing Process (防潮包装过程)

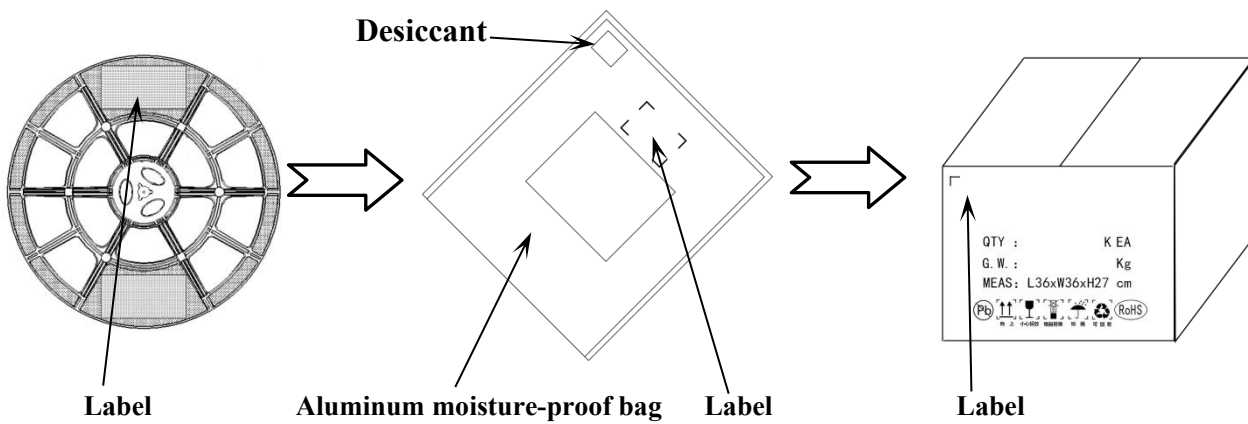

Note (备注) :

1. The cathode is oriented towards the tape sprocket hole in accordance with ANSI/ELARS-481 specifications
负极朝向定位孔, 符合 ANSI/ELARS-481 规格。

Precautions for use Over-current-proof (通电使用时的注意事项)

Customer must apply resistors for protection otherwise slight voltage shift will cause big current change (burn out will happen).

客户必须使用电阻进行保护，否则轻微的电压变化会引起大电流变化（会发生烧坏）。

Storage (存储)

1. Do not open moisture proof bag before the products are ready to use.

在使用之前禁止打开防潮包装。

2. Storage conditions prior to uncapping : 5 - 30 °C , maximum relative humidity of 60%.

开封前的贮藏条件：5-30°C，最大相对湿度为 60%。

3. After opening the package, The LEDs should be soldered within 4 hours after opening the package.

打开包装之后,应在 4hrs 内焊接完毕。

Soldering Condition (焊接条件)

1. Number of reflow process shall be less than 2 times and cooling process to normal temperature is required between first and Second soldering process.

本产品最多只可回流焊两次,且在首次回焊后须冷却至室温之后方可进行第二次回流焊。

2. Recommended soldering conditions:

推荐焊接条件:

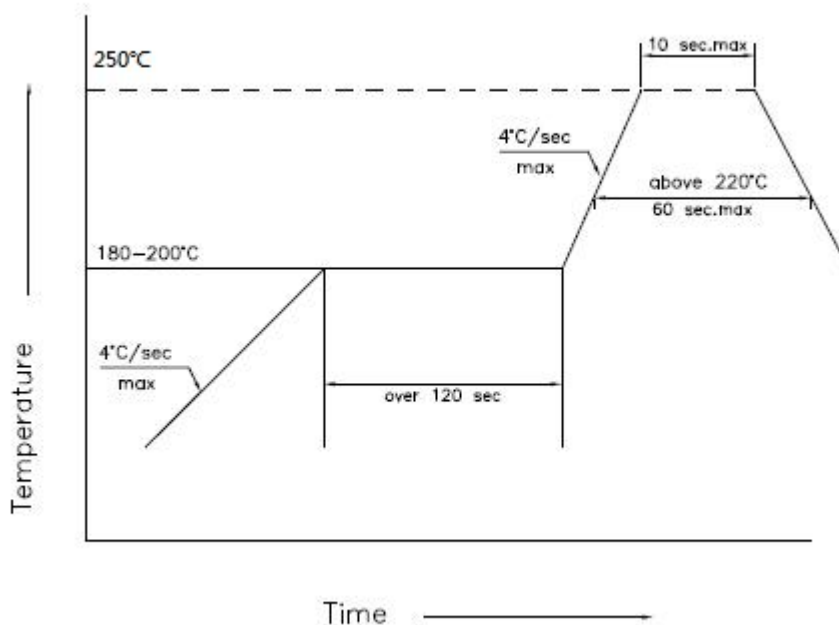

3. LED operating environment and sulfur element composition cannot be over 25 PPM in the LED mating usage material.

LED 工作环境及与 LED 适配的材料中硫元素及化合物成份不可超过 25PPM。

Soldering Iron (烙铁焊接)

1. When hand soldering, keep the temperature of iron below less 250°C less than 10 seconds.
当手工焊接时，烙铁的温度必须小于 250°C，时间不可超过 10 秒。
2. The hand solder should be done only one time.
手工焊接只可焊接一次。

Repairing (返修)

Repair should not be done after the LEDs have been soldered. When repairing is unavoidable, a double-head soldering iron should be used (as below figure). It should be confirmed beforehand whether the characteristics of the LEDs will or will not be damaged by repairing.

不应在 LED 焊接后进行修复。当修复不可避免时，应使用（如下图）之类的双头烙铁，应事先确认此种修补方法会不会损坏 LED 本身。

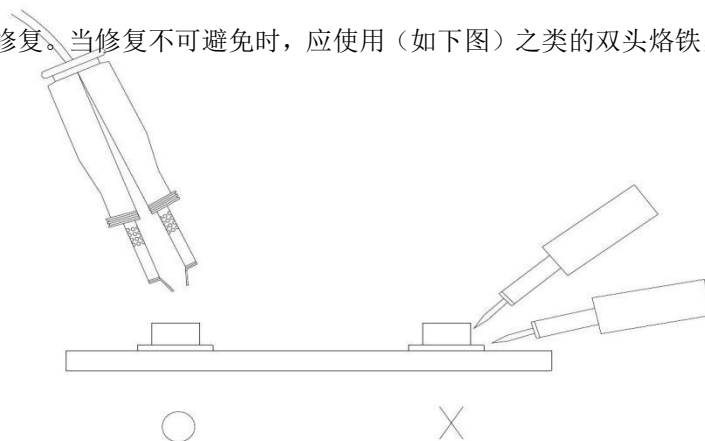

Cautions: (使用注意事项)

1. Please check if there is air leak before opening the package, if so, please return the goods back to take drying process for later using.
在开包装之前，请先检查包装袋有无漏气，如果有漏气现象，请退回我司重新烘烤除湿包装后再使用
2. Products can be used within 6 months after packaging, after that, they must be:
抽真空包装材料未超过 6 个月可正常使用，包装袋开启后,产品必须:
 - A.Soldered within 4 hrs;
A.在 4hrs 内焊接完毕;
 - B.Used in the condition: 30°C within and 60%RH below.
B.使用条件需：温度:30°C 以内，湿度:60%RH 以下。
3. The vacuum packaging material is not used for more than 6 months after being packaged unless opening the package and take drying our process in 70°C/12H.
抽真空包装材料超过 6 个月未使用，再使用时需重新拆铝箔袋取出烘烤 70°C/12H 除湿后才可使用。